

PUMP PRIMING -**ISSUE**

Some [REDACTED] Spas have experienced priming difficulties.

SCOPE

This service bulletin applies to all 2003 [REDACTED] 2- pump, and 1-pump [REDACTED] spa models with serial numbers before [REDACTED]

SERVICE DETAIL

A few dealers have reported difficulties in priming some [REDACTED] spas.

SOLUTION

A new procedure has been implemented to improve pump priming on [REDACTED] spas. This involves tying the pump bleeder valves together and connecting them to the Heater-Bypass-Tee and using suction from the circulation pump to help speed the priming process. A Field Repair Kit to provide all necessary parts has been assembled for your convenience.

If you have any questions, you may contact the [REDACTED] for additional guidance. They may be reached by calling [REDACTED] or on the web at [http://www.\[REDACTED\]](http://www.[REDACTED])



Field Repair Kit [REDACTED]

Instructions for installing the 2-pump priming solution:

- Step 1:** Drain all water from spa.
- Step 2:** Remove spa panel below the Top Side Control to gain access to Lower Equipment Compartment.
- Step 3:** Assemble necessary tools:
- ① Hose Clamp Grip
 - ② Needle Nose Pliers
 - ③ Plastic Hose Cutter
 - ④ Vise Grip
 - ⑤ Phillips Head Screwdriver
- Step 4:** Use Phillips Head Screwdriver ⑤ to remove hose clamp holding the pipe corner to the compartment wall. Pipe corner is located in the upper right corner of the Lower Equipment Compartment.



PUMP PRIMING -

Step 5: Use the Plastic Hose Cutter ⑤ to cut as close to the edges of the pipe corner as you can, in order to leave as much hose as possible.

Cut out the Angle



Step 6: Open the Field Repair Kit and take out new plastic "T" Adapter. Apply clear PVC glue to the 1/2" white flex hose and into right side of "T" Adapter, then insert the white flex hose into "T" Adapter.



Step 7: Next, place the large wire hose clamp over the end of clear vertical pipe coming from the Heater-Bypass-Tee and then insert the barbed male end on the bottom of "T" Adapter into the clear pipe. Use the special Hose Clamp Grip ① (or the Vise Grip ④) to place the hose clamp into position.



Step 8:

2-Pump Spas Only



Take the clear pipe assembly from the Field Repair Kit and unwrap it.

Rotate tubing so that the shortest piece is pointed up, the longest piece is pointed to the left, and the 2nd longest piece is pointed to the right.



Next, string the 2nd longest piece of tubing behind the Heater-Bypass-Tee and to the front of the Mazzei-Tee as shown. The longest piece is routed behind the equipment on the left and extended to the pump on the left.

Step 8:

1-Pump UltraPure™ Spas Only



Take the clear pipe assembly from the Field Repair Kit and unwrap it.

Find the longest section of plastic tubing. Use the Plastic Hose Cutter ⑤ to cut as close to the edge of plastic "Tee" as you can. You can discard the rest of this assembly.



Next, string the piece of tubing behind the Heater-Bypass-Tee and to the front of the Mazzei-Tee as shown. The plastic tubing is then routed behind the equipment and extended to the pump, located on the lower right side of the compartment.

PUMP PRIMING -



Be careful to route the tubing as indicated to ensure that space remains available for the [REDACTED] should it be installed now, or in the future.

Step 9:

After the tubing has been routed correctly, apply clear PVC glue to barb on the 3/8" 90° barbed end of "T" Adapter and insert barb into shortest piece of clear tube.

Press it on tightly.



Step 10:

2-Pump Spas Only

Take the "free end" of the 2nd longest piece of tubing and extend it to right side of pump #1 – located on right of the Lower Equipment Compartment.

Locate the Bleeder Plug shown in the circle in the picture. Measure how much hose will be necessary to reach that location. Add another 2" to that measurement, for slack, and cut the tubing with the Plastic Hose Cutter

③.

Use the Needle Nosed Pliers ② to remove the Bleeder Plug.

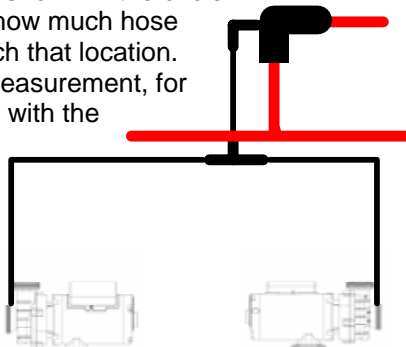

Step 10:

1-Pump UltraPure™ Spas Only

Take the "free end" of the piece of tubing and extend it to right side of the pump – located on right of the Lower Equipment Compartment.

Locate the Bleeder Plug shown in the circle in the picture. Measure how much hose will be necessary to reach that location. Add another 2" to that measurement, for slack, and cut the tubing with the Plastic Hose Cutter

③.

Use the Needle Nosed Pliers ② to remove the Bleeder Plug.

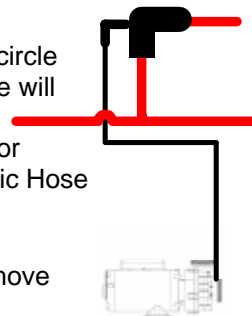

PUMP PRIMING -

Step 11: Remove the Barbs from the Field Repair Kit. Add a bead of silicon, or Teflon tape, to one of the barbs and insert it into the empty Bleeder Plug port on Pump #1.



Screw it in finger snug and then use the Needle Nose Pliers **2** to tighten it another ½ turn. Be sure it points up when done.

Next, place a small wire hose clamp over the end of clear tubing. Then apply clear PVC glue to the barb and press the end of the clear tubing over the barb. Finally, use the special Hose Clamp Grip **1** (or the Vise Grip **4**) to place the hose clamp into position.



Step 12: Repeat Step 11 using the other barb and Pump #2, located on the left side of the Lower Equipment Compartment.

*2-Pump
Spas Only*

Step 13: When all tubes have been connected, replace the clamp on the "T" Adapter as shown. Use the Phillips Head Screwdriver **5** to secure the clamp and adapter to the wall.



Step 14: Open, or remove, the Bleeder Valve(s) located near the filter canisters. Refill the spa through the [REDACTED] or filter, canister until the water level is 6" below the top of the spa shell. Then turn on the pumps. After the pumps have been successfully primed, replace and tighten the Bleeder Valves.

*2-Pump
Spas Only*



Step 14: Open, or remove, the Bleeder Valve(s) located near the filter canister. Refill the spa through the filter canister until the water level is 6" below the top of the spa shell. Then turn on the pumps. After the pumps have been successfully primed, replace and tighten the Bleeder Valves.

*1-Pump
[REDACTED]
Spas Only*



[REDACTED]
Service Manager