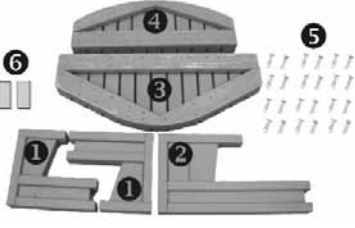

# Bay Collection

## Step Assembly Instructions

Parts List			Tools List	
Description			☆	
1	Small Riser (2)	☆	Cordless Drill with a phillips head bit	
2	Large Riser	☆	Phillips Screwdriver	
3	Large Top Step	☆	Tape Measure	
4	Small Bottom Step	☆	#2 Lead Pencil	
5	Bag of Wood Screws			
6	Wooden Assembly Spacer			

### Getting Started

Open both boxes and spread out the parts as shown above. Assembly is as simple as 1-2-3.

### Assemble Top Step

- 1 Take the Top Step **3** and turn it upside down.



- 2 Next, take the Large Riser **2** and place it in the center of the inverted top step. You can use the tape measure and pencil to mark a center line 18" from either end. Then center the Large Riser on the line as shown. Make sure the flat edges of the Top Step and the Large Riser are "flush."



- 3 Take the phillips screwdriver or cordless drill with a phillips tip and screw in wood screws into the four "pre-drilled" holes in the riser as shown. Be sure the edges of the riser and the step are flush before you secure with the screws.

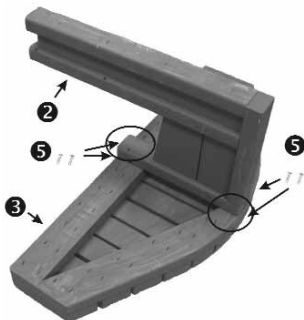

### Assemble Small Risers

- 1 Place a Small Riser **1** on the edge of the Top Step and position as shown below. Use the Wooden Assembly Spacer **6** to measure from the edges of the Top Step as shown. Make sure that the long edges of the Top Step and the edges of the Small Riser are "flush" before you secure them to the Top Step with 2 Wood Screws on each side. Each Small Riser has four "pre-drilled" holes to help you.



- 2 Next, position the other Small Riser **1** on the opposite side, using the Wooden Assembly Spacer **6**, as shown above. Make sure that the long edges of the Top Step and the edges of the Small Riser are "flush" before you secure them to the Top Step with 2 Wood Screws on each side. Each Small Riser has four "pre-drilled" holes to help you.



- 3 When all the Risers are correctly assembled, they will look like the example above.

### Assemble Small Step

- 1 When you have finished securing the Risers to the Top Step, rotate the step assembly forward so that the flat side is "up." Place the Wooden Assembly Spacers and position them in the angle of the Small Risers as shown below.

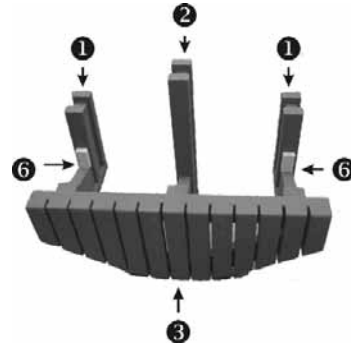

- 2 Next, take the Small Bottom Step and insert it into the flat area of the Risers. The flat edge of this step will rest on the Wooden Assembly Spacers. You will know that you have it positioned if the round edges of both steps are facing in opposite directions.



- 3 Make sure that the edge of the Risers do not extend beyond the edges of the Small Top Step. Then secure the Small Top Step to the Risers using the remaining Wood Screws.

  
**DIMENSION ONE SPAS®**  
 A Higher Degree of Indulgence™  
[www.D1Spas.com](http://www.D1Spas.com)