

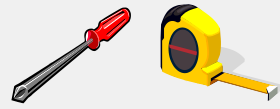

Parts List

- 2 - Slide Rails **a b c**
- 4 - End Brackets (2-long, 2-short) **d**
- 2 - Bags of Assorted Nuts & Bolts
- 1 - Quick Connect Guide
(this document)

Tools List



Quick Connect Guide

Chassis Trak[®] Rack Slides

1 Prepare Slide Rails for Assembly

Remove slide piece **a** from the assembly. The remaining assembly includes slide piece **c** inside slide piece **b**. The end bracket **d** will be added to slide piece **b** in Step **3**.

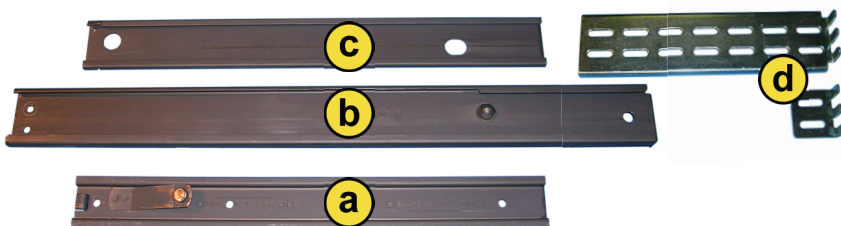

2 Attach Rail to Chassis

Attach Slide piece **a** to the side of the chassis. Position the spring end toward the rear of chassis. Place as far forward as the hole alignment allows. Attach rail section to both sides of chassis before continuing.

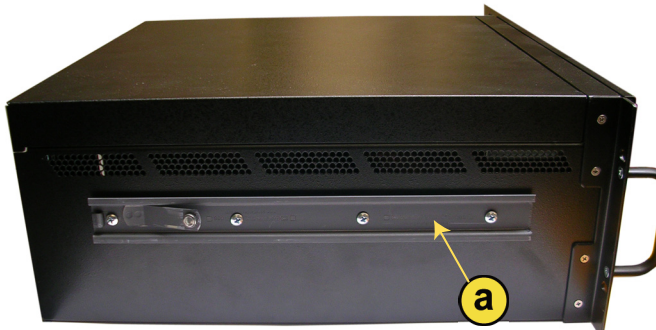

Be sure to use all 4 screws in side each for added safety.

3 Assemble Slide Rails

Measure the rack from front to back so you can confirm how long the rail must be to fit properly.

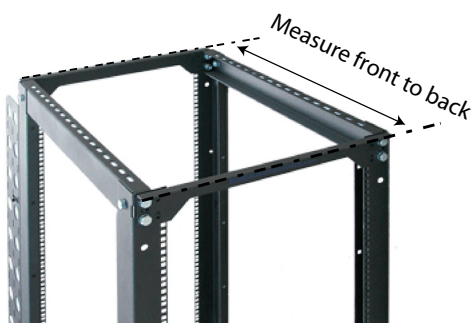

Next, assemble Slide piece **b** with end bracket **d** as shown and secure with 2 Panhead screws and locking nut. Ensure the Phillips screw head is located on the "open" side of the Slide pieces as shown. Tighten finger tight only to allow for minor adjustment during assembly in the Step **5**.



Depending on the depth of your rack you may select either the long or the short end bracket **d**.

4 Add Screws to Rack Post

Attach 2 Panhead screws into rack post where you want the chassis mounted. Be sure you have measured accurately to ensure that everything fits in the rack correctly. Leave the screws untightened until after you place the slide rail's fingers (Step **5**) between the screws as shown.

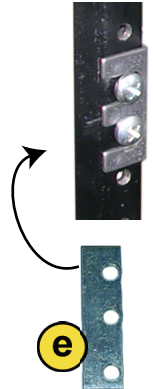

If your rack has holes too large for the screws, you can use the Bar Nut **e** to secure your mounting by inserting the Panhead screw through the rack hole and screwing it into the Bar Nut on the reverse side of the rack post, as shown. Notice that the holes on the Bar Nut are spaced unevenly to accommodate different racks.

5 Attach Slide Rail to Rack

Attach to inside of rack with "fingers" pointing "out" and the end bracket to the rear. Secure each Slide Mount with 4 screws as shown below.

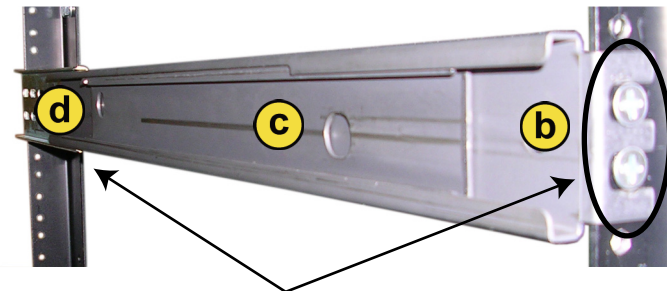

Secure with 2 screws to both front and rear posts. After you have secured the slide rail fingers to the rack posts, tighten the 2 screws used to attach the slide rail **b** to the end bracket **d**.

6 Attach Chassis to Slide Rail

Extend slide piece **c** out until the safety catch engages. Do this for both sides. Next, insert the slide rail **a** inside the grooves on slice part **c** as shown. Push in until it stops.

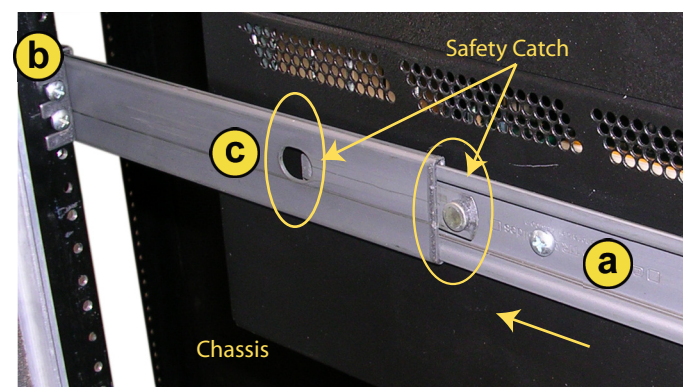

Next, press on the safety catch on slide piece **a** and continue to push until it stops again. Press on the safety catch again to allow the chassis to slide all the way into the rack.

7 Secure the Chassis to the Rack

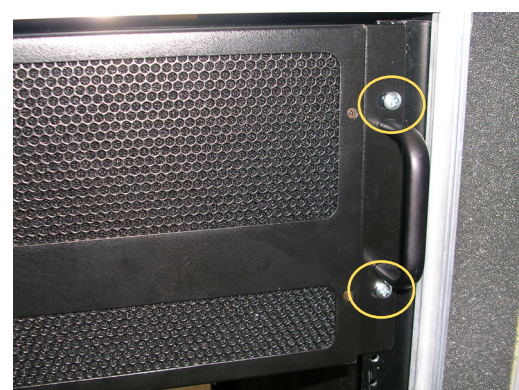

Use 2 Panhead screws, on each side, to secure the chassis to the rack as shown.